

# ... SBS-SBL

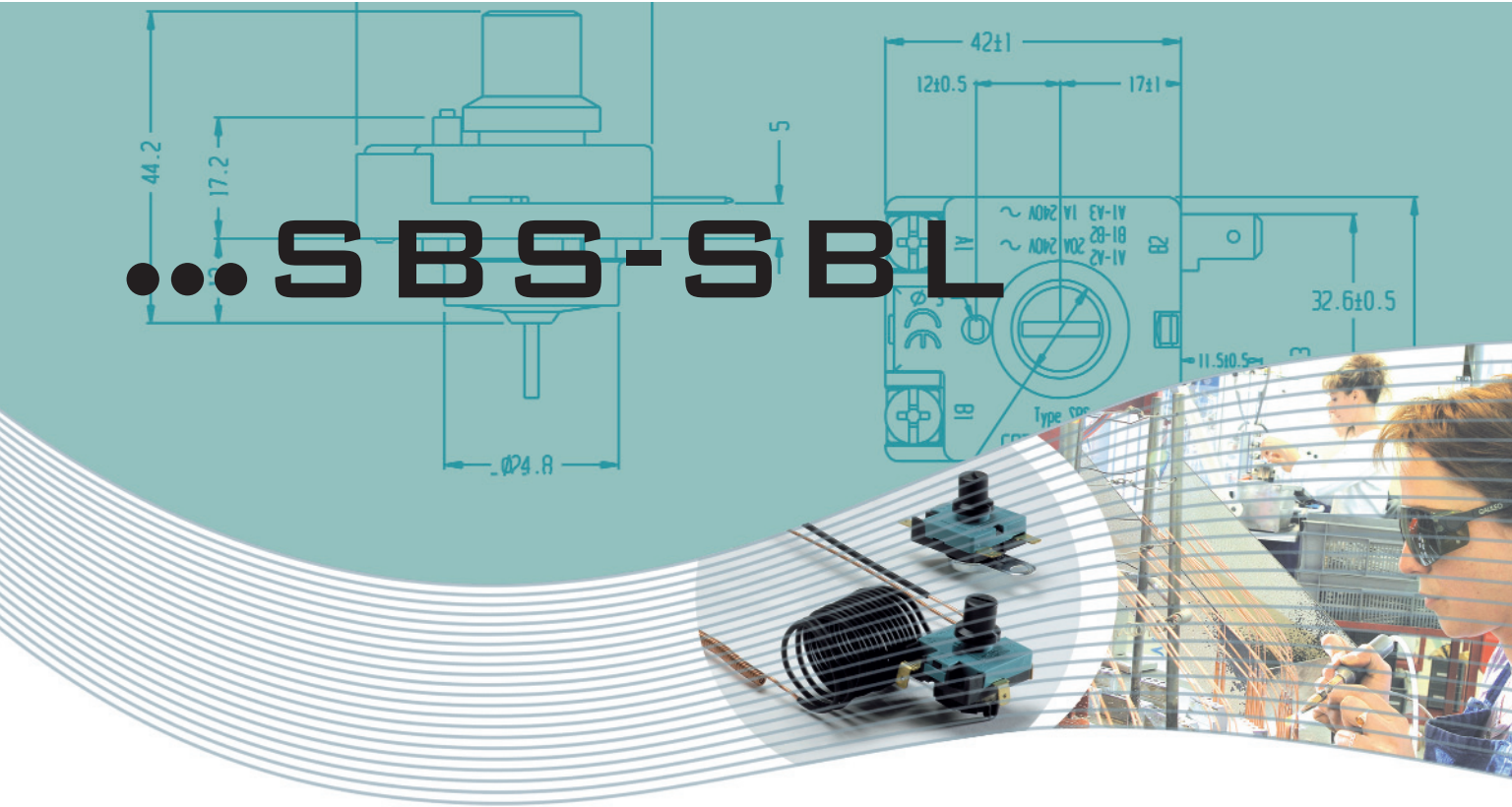

## → DESCRIPTION

Double pole safety limiter with manual reset

## → FEATURES

- Fast reaction time
- Choice of configurations for function (SBS) and cost optimization (SBL)
- Optimized reading of temperature in immersion applications
- Non self resetting limiter
- Guarantee of safety operation : fail-safe capillary
- Factory pre-set fixed temperature
- Possibility for changeover contact on double pole version
- Available in single pole version with automatic reset

## → OPERATION

**Capillary** : the liquid within the capillary is transformed to vapor with an abnormal increase in temperature. The increase in volume acts on a mechanism to open electrical contacts. In case of damage to the capillary the fail-safe limiter operates automatically. The limiter is manually resettable.

**Bimetal** : a snap action bimetal opens electrical contacts with an abnormal increase in temperature

## TECHNICAL CHARACTERISTICS

	SBSC	SBSC3	SBSCA	SBSB	SBLC
Type	Single or double pole single throw (SPST or DPST) capillary limiter with manual reset	Double pole double throw (DPDT) capillary limiter with changeover contact and manual reset	Single pole single throw (SPST) capillary safety limiter with automatic reset	Double pole single throw (DPST) bimetal limiter with manual reset	Double pole single throw (DPST) capillary limiter with manual reset
Safety limiter temperature	Fixed 75°C - 120°C / 167°F - 248°F				
Rating	20A - 240V				
Material	Copper or nickel plated copper				
Capillary length	150 to 3 000 mm / 6 to 118"				
Safety limiter capillary	Spiralled or single / double / triple bent				
Maximum head temperature	110°C / 230°F				
Connections	Brass faston or pillar terminals				
Approvals	CE, EN60730				

# ...SBS-SBL

## TECHNICAL CHARACTERISTICS



Electric water heater



Solar water heater



Electric heating



Electric radiator



Towel dryer



Boiler



Heat pump



Fan heater / ventilation



Air conditioning



Sauna



Pool & Spa



Coffee machine



Wine cabinet



Dish washer



Washing machine



Oven (domestic and industrial)



Rotisserie



Warming drawer



Deep fryer



Commercial cold



Bain marie



Medical equipment



Industrial equipment

### SBS

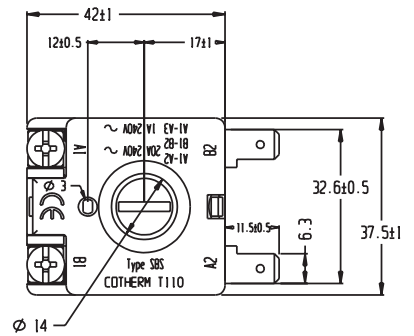
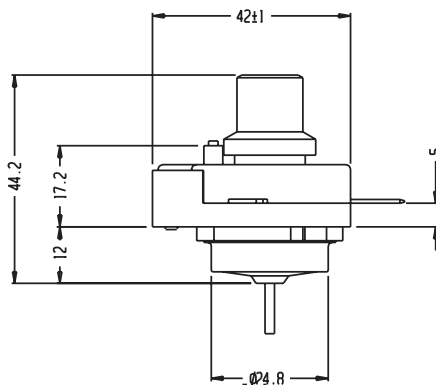
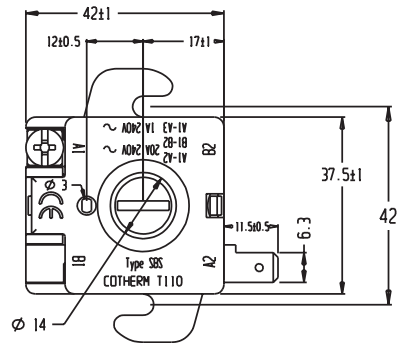
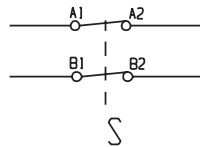

### SBL

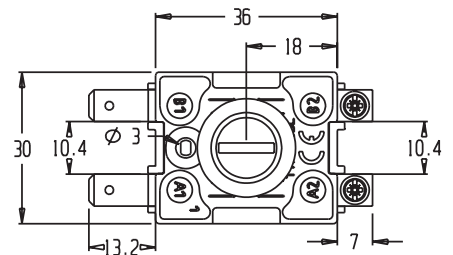
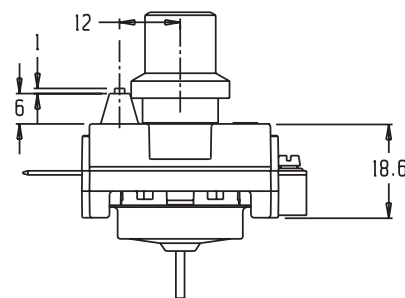

**Weight :**  
SBS = 70g / SBL = approx. 35g

COTHERM reserves the right to bring any modifications to our products.  
We manufacture products according to drawings which serve as contractual documents.  
We are not responsible for damage resulting from inappropriate installation or use of our product.